

Pendant Light Fittings BDD81 Series Explosion-proof Lightings

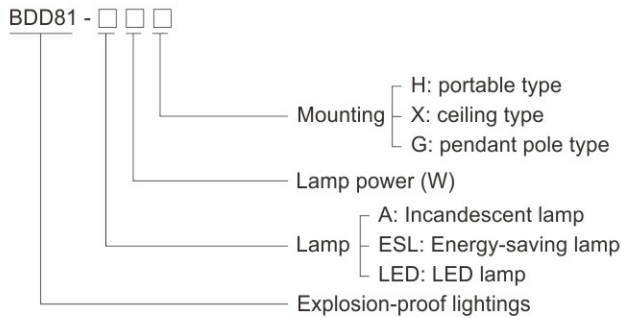

- ◆ Explosion protection to
 - CENELEC
 - IEC
 - NEC
- ◆ Can be used in
 - Zone 1 and Zone 2
 - Zone 21 and Zone 22
 - Class I, Zone 1 and Zone 2
 - Class I, Division 1, Groups A, B, C, D
- ◆ Available lamp and power :
 - Incandescent lamp: 25W, 40W, 60W, 100W
 - Energy-saving lamp: 9W, 11W
 - LED lamp: 3W, 5W, 8W
- ◆ Enclosure in Copper-free Aluminium Alloy, powder coated surface, yellow (RAL1021).
- ◆ The light fittings are supplied without lamp. PHILIPS lamps are recommended.

Catalogue number logic



Mounting type (all dimensions in mm) – subject to alteration

Installation reference

	H: portable type	X: ceiling type	G: pendant pole type
<p>100W Incandescent lamp</p> <p>11W Energy-saving lamp</p> <p>8W LED</p>	<p>Weight: 2.70kg Accessories supplied with the light fittings: ①. Hook ②. 4 x M25 x 1.5 Plug; Ex d cable gland (optional); DQM-II (Ex d) or DQM-III (Ex d) is recommended. Please see P7/20-29.</p>	<p>Weight: 2.50kg Accessories supplied with the light fittings: ②. 4 x M25 x 1.5 Plug; Ex d cable gland (optional); DQM-II (Ex d) or DQM-III (Ex d) is recommended. Please see P7/20-29.</p>	<p>Weight: 4.50kg Accessories supplied with the light fittings: ③. BGJ-III explosion-proof connector M25 x 1.5(M)/M25 x 1.5(F), Stainless steel. ④. Straight pipe(M25 x 1.5), length: 300mm. ⑤. BHD51-F (Ex d IIC, Copper-free Aluminium Alloy), see P3/4.</p>

Zones 1&2; 21&22

Pendant Light Fittings BDD81 Series Explosion-proof Lightings

Technical data	
Explosion-proof lightings	BDD81-□□□
Explosion protection	
Global (IECEX)	IECEX CQM 12.0036X
Gas and dust	Ex d IIC T4 Gb
	Ex t IIIC T130°C Db IP66
Europe (ATEX)	LCIE 11 ATEX 3110X
Gas and dust	⊕ II 2 G Ex d IIC T4 Gb
	⊕ II 2 D Ex t IIIC T130°C Db IP66
Certificates	IECEX; ATEX; CU-TR
Conformity to standards	EN 60079-0, EN 60079-1, EN 60079-31 IEC 60079-0, IEC 60079-1, IEC 60079-31
Material	
Enclosure	Copper-free Aluminium Alloy, powder coated surface, yellow (RAL1021)
Transparent cover	Toughened glass, stands 4J impact
Wire guard	Stainless steel
Exposed fastener	Stainless steel
Lamp	
Lamp holder	E27
Available lamp and lamp power (W)	Incandescent lamp: 25W, 40W, 60W, 100W Energy-saving lamp: 9W, 11W (for sealed atmosphere) LED: 3W, 5W, 8W
Rated voltage	220~240V AC 50/60Hz
Earthing protection	M5 (internal & external earth bolts)
Degree of protection	IP66, IP67(optional)
Ambient temperature	-40°C~+55°C
Terminal	3 x 1.5~4mm ² (L+N+PE)
Mounting	Portable type, ceiling type, pendant pole type
Cable entries	4 x M25 x 1.5 for ceiling type and portable type, 1 x M25 x 1.5 for pendant pole type
Cable gland (optional)	DQM-II (Ex d) or DQM-III (Ex d) is recommended. Please see P7/20~29.
Applicable cable outer diameter	Φ10~Φ14 (mm)



Photometric data Note: LED luminous flux is from the standard product of which colour temperature is 5400 to 6500K (cool white).

BDD81-A□□

Rated luminous flux
25W Incandescent lamp: 201lm
40W Incandescent lamp: 318lm
60W Incandescent lamp: 500lm
100W Incandescent lamp: 1025lm
The data from Philips lamp

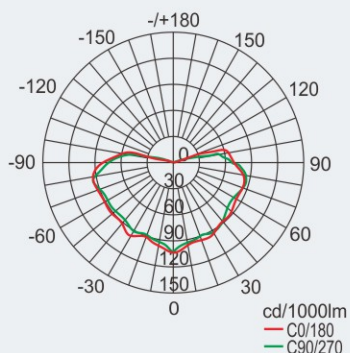

BDD81-ESL□□

Rated luminous flux
9W Energy-saving lamp: 400 lm
11W Energy-saving lamp: 570 lm
The data from Philips lamp

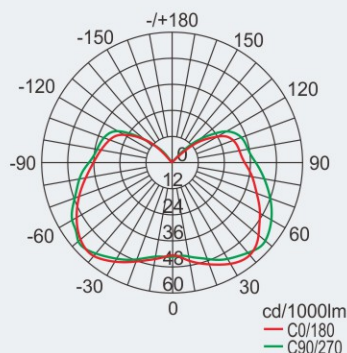

BDD81-LED□□

Rated luminous flux
3W LED: 255lm
5W LED: 425lm
8W LED: 680lm

